

SmartRooms

Thermal Comfort System

By Therma-Ray

EARTH STORAGE SYSTEM

Installation Guide

Whether you're a contractor, architect, builder or homeowner, creating the perfect indoor environment has always been a challenge. Therma-Ray, the world's #1 name in thermal comfort systems introduces you to the ultimate solution, SmartRooms. Please take the time to read this installation guide carefully before you begin. Remember, accurate measurements are the key to success for a proper installation

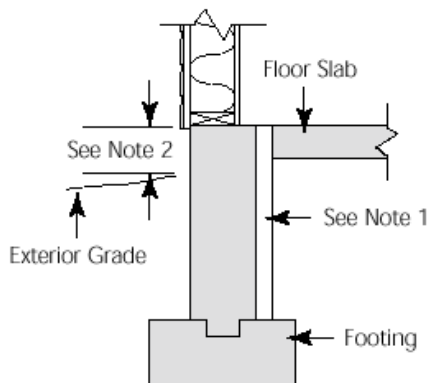

Diagram 1 Note 1. All insulation shown is 2 inch thick closed cell polystyrene type SB. Installed from top of slab to top of footing or 4 ft. horizontally from inside of foundation.

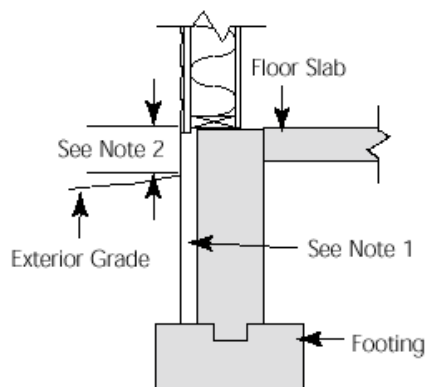

Diagram 1 Note 2. If more than one foot of foundation wall is exposed above grade, the insulation thickness should be increased to 4 inches.

PLANNING AND LAYOUT

Primary Heating Systems – When the SmartRooms Earth Storage System is the main heat source for the building a detailed heat loss calculation must be performed to ensure a successful installation. Consult your Therma-Ray representative.

A scale layout or sketch should be provided, showing the placement and type of panels, junction box locations and thermostat type & locations. All below-grade construction, such as footings, column bases, drains, plumbing & electrical lines, which might affect the location of the panels, should be indicated on the layout.

Inspection upon arrival of the panels should be made for any damage that may have happened in transit. If delivered by common carrier, immediately report damage or missing materials to the trucking company. For problems with other means of delivery, contact your Therma-Ray distributor. Check the operating voltage marked on the panels to make sure it matches the building supply voltage.

Outside storage of the panels is permitted, provided that the protective moisture-proof plastic cover and tarp is intact and the panels are protected from physical damage.

INSTALLATION IN OR ON TOP OF SAND FILL

Site Preparation – Ground water conditions will cause problems if there is moving water present within the building area. Should moving water exist at the site, a soil engineer should be consulted as to the feasibility of using footing drains or other drainage methods to correct the problem. A high water table that is NOT MOVING or changes very slowly with the seasons is generally not a problem. In such cases a vapour barrier should be installed.

Perimeter insulation must be installed to ensure an efficient heating system. Failure to insulate the slab correctly may cause difficulty in maintaining the desired building temperature and/or cause excessive heating costs. Insulation that will be in contact with the ground should be a type SB foamed, closed-cell polystyrene. Other types of insulation, such as foamed urethane or polystyrene bead-board, will absorb a certain amount of ground moisture that will reduce its effectiveness. Refer to **Diagram 1** of this installation guide for the proper methods of installing the perimeter insulation for various slab configurations. Consult your Therma-Ray Representative for alternate configurations if necessary.

The difference between heat and comfort.

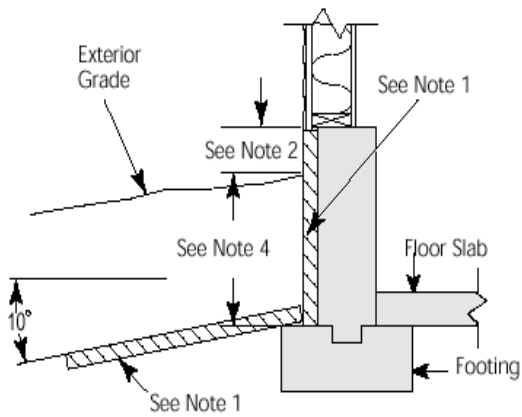

Diagram 1 Note 3. If top of footing is a minimum of 6 ft. below exterior grade, insulation may be installed to a depth of 4 ft. below grade. Otherwise the insulation should be installed to top of footing.

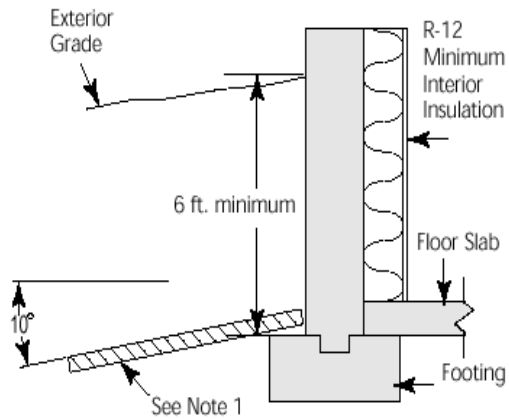

Diagram 1 Note 4. All footings must be below the frost line.

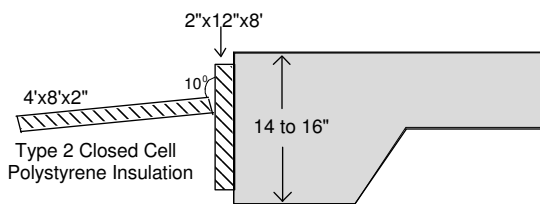

Diagram 1 Note 5 – Floating Slab

Filling and grading may be started after all below-grade insulation is installed. Any under slab plumbing or electrical lines should be roughed in before filling to avoid disturbing compacted fill or damaging panels. Good practice requires a minimum of 4 to 6 inches of compacted granular fill to provide adequate drainage if slab moisture problems are to be avoided. When panels are used to provide an OFF-PEAK STORAGE SYSTEM, they are usually installed with additional sand fill above them. If design specifications require fill above panels, DO NOT FILL TO FINAL GRADE until panels are installed. If need be, spread a minimum of two inches of sand as protection against sharp stones in the subsoil before placing panels and to protect supply wiring. **Refer to Diagram 2.**

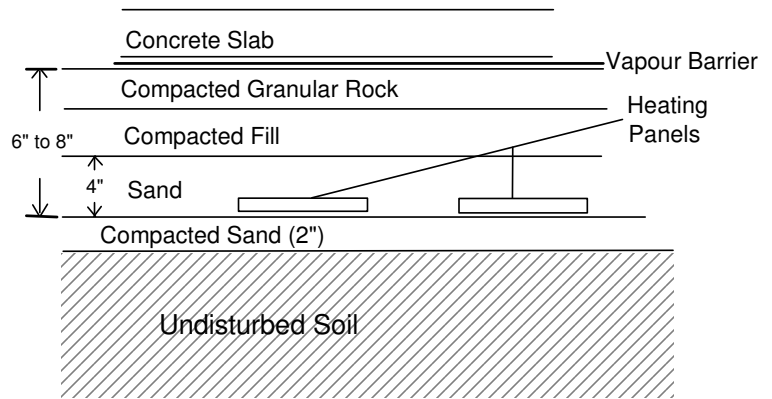

Diagram 2

Fill material should be granular material with good compaction qualities to provide drainage and a stable base for the slab. Materials such as unwashed, unscreened bank run gravel or sand are preferred. If there is any doubt about the acceptability of the fill contact your Therma-Ray representative. Any large stones, which would interfere with or damage the panels, or wiring should be removed.

A vapour barrier should be installed according to local building codes. An approved vapour barrier at least 6 mil thick should be used and placed on the fill directly under the slab. If panels are to be placed in contact with the slab, the vapour barrier may be installed on top of the panels.

Panel Installation

1. All work done under this section must comply with any national or local building codes.
2. To avoid damage by other trades, all below-grade plumbing and electrical work must be roughed in before positioning panels. If floor area is large enough to require screeds or forms, locate the screed stake line and avoid placing the panels in this area.
3. Position panels as designed. To prevent damage to panels due to possible settling of the sand, panels should not be placed partly on column bases and partly on the sand.
4. Branch circuits run in concrete must have the conductors installed in non-metallic conduit. Conduits must not cross expansion or construction joints. The use of conduit may be avoided if conductors feeding the panels are placed in the sand fill under the slab. Wire approved for direct burial must be used. Single conductor USE or 2-conductor RWU wire is recommended. Conductors entering or leaving the slab must be protected with conduit.

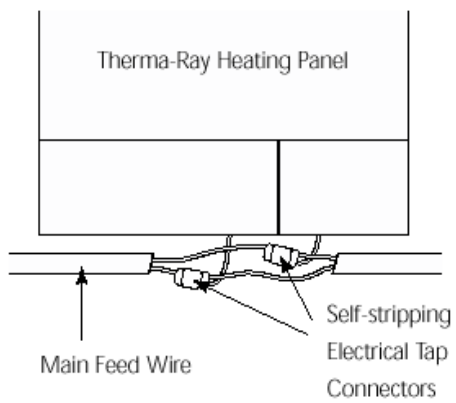

Diagram 3. Connecting the main feed to the indiv panel is easily done using tap-on connectors. Note that ONLY the outer insulation jacket of the main feed is removed.

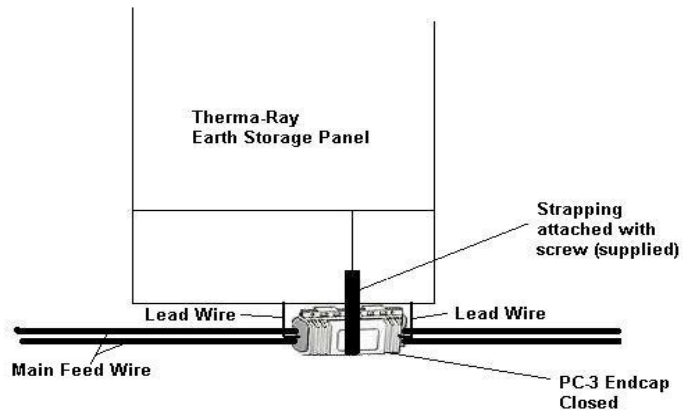

Diagram 3 – Note 3

The 3M connectors are inserted into the gel and can be easily removed from the gel if required for inspection or testing.

3M567 Self Stripping Electrical Tap Connectors

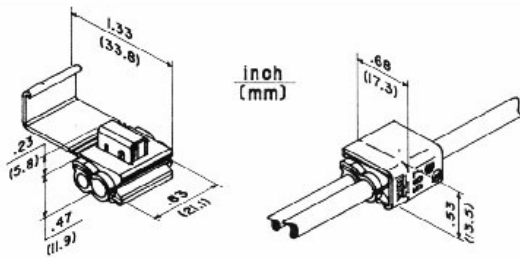
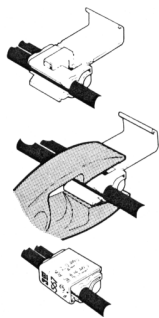

Diagram 3 – Note 2



INSTRUCTIONS
Use only with insulated wire. Do not strip insulation.

1. Slip circuit (run) wire into side slot. Insert fixture (tap) wire up to stop.
2. Make connection with 9" electrician's (lineman's) pliers, by driving "U" contact down flush with top of connector.
3. Close hinged cover until it locks.

5. Branch circuits must have an amp rating equal to 125 percent of the connected panel load per N.E.C. Run branch circuits to pick up connections at each panel. **Refer to Diagram 3** for panel connection procedure. Connect panels parallel to the branch circuit using 3M No.567 self-tapping connectors. When using USE wire, only #12 AWG should be used. When using RWU wire, #10 AWG or #12 AWG may be used. **Refer to Diagram 3-Note 2.** Insert the now connected cables into the endcap gel. Using the strap, draw the endcap as tightly as possible to the panel, then affix the strap using the supplied screw. **Refer to Diagram 3- Note 3.**
6. It is highly recommended to use ½" flexible conduit with a glued cap for the high limit sensor. This is to be placed on top of one of the ES heaters and runs from the panel back to the thermostat location (maximum 15').
7. A final test of the panels and connections is required at this point. Although all panels are fully tested at the factory, a test of the field-connected system should be performed. Record test readings made during this step. After back fill and tamping another reading must be taken and recorded. This reading must match the first reading.
8. A second ½" flexible conduit with glued cap for the floor sensor may be tied to the mesh (maximum 15'). After slab is poured and before connecting branch circuit to distribution panel, another set of readings should be recorded and compared with the first set of values. Failure to record the readings as outlined will void the warranty.

Read the resistance between the two branch circuit conductors with an ohmmeter. If circuit is connected to the distribution panel, make sure circuit breaker is "off" or reading may include the resistance of other branch circuits. If the reading agrees with the value calculated using the formula below, then circuit is OK.

Example: For branch circuit of 1500 watts and rated panel voltage of 240V, the resistance is 38.4 ohms.

$$\text{Formula: } \frac{\text{voltage} \times \text{voltage}}{\text{wattage}} = \text{resistance in ohms, Example: } \frac{240 \times 240}{1500} = 38.4 \text{ ohms}$$

Recheck connections to any suspect panel. If connections are OK, then replace unit and recheck readings. Should Therma-Ray LOADCHECK sheets be provided with the job, they must be completed per their attached instructions.

Preparation for pouring floor

9. If sand fill over panels is specified, fill to final grade. Fill must be well compacted.
10. If required, install vapour barrier. If there is no fill above panels, it may be installed on top of the panels.
11. If screeds will be used, screed stakes should only be driven in areas designated by electrical contractor to avoid damaging panels and branch circuit wiring.
12. Install conduits for in-slab temperature sensor. Refer to control installation (**Diagram 4**). If high temperature cut-outs are required, install conduits for cut-outs. (High temperature cut-outs are required whenever panels are not in contact with the concrete slab.) Refer to the thermostat instruction sheet for installation details.

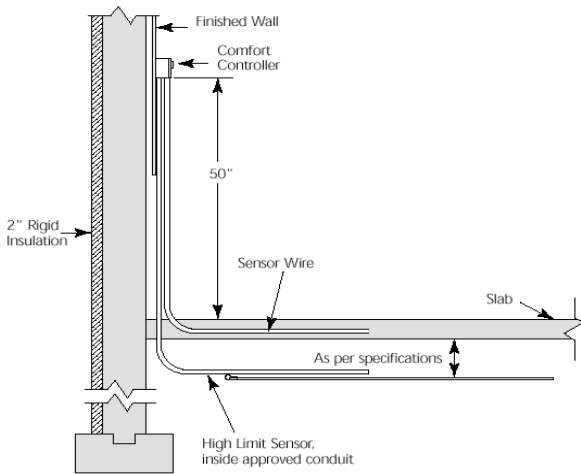

Diagram 4

Therma-Ray Inc.

670 Wilsey Road, Unit 6
 Fredericton, NB Canada E3B 7K4
 Toll Free: 1-866-457-4600
 Tel: 506-457-4600
 Fax: 506-457-4699
 E-mail: sales@thermaray.com
www.thermaray.com
 Printed in Canada

Pouring concrete

13. The slab and foundation must be installed in accordance with state and local codes.
14. All workers should be cautioned to use care with shovels, rakes and other equipment, to avoid damaging panels and branch circuit wiring.
15. When large floor areas are involved, consideration should be given to the method of pouring concrete, i.e. pumping, truck chute, etc. It may be advisable to lay panels one or two bays at a time. This will allow equipment to use adjacent bays to deliver concrete to bay being poured.
16. DO NOT ENERGIZE PANELS until slab is fully cured. Slab strength may be affected by rapid curing. Contact Therma-Ray for proper procedures.

EARTH STORAGE SYSTEM

CATALOGUE #	VOLTAGE	WATTS	WIDTH "	LENGTH '	WEIGHT lbs
ES7C-515-208	208	515	18	7	21
ES5C-300-208	208	300	18	5	15
ES7C-460-240	240	460	18	7	21
ES5C-320-240	240	320	18	5	15
ES4C-280-240	240	280	18	4	12
ES7C-460-277	277	460	18	7	21
ES5C-300-277	277	300	18	5	15
ES7C-480-347	347	480	18	7	21
ES5C-335-347	347	335	18	5	15
ES4C-260-347	347	260	18	4	12
ES3C-200-347	347	200	18	3	9

ACCESSORIES

- PC-3 Gelcap
- 3M567 Connector for #12 wire
- SR-LV SmartRooms Comfort Controller Low Voltage (Note: must be used with SmartRooms control panels.)
- SR Sensor Sensor
- SRDP2 SmartRooms Relay Panel

SmartRooms

Thermal Comfort System

By Therma-Ray

Revised: October 25, 2012